

Tohum İşleme ve İyileştirme Teknolojik Çözüm ortağınız

Your 'Seed Processing & Conditioning' Partner.

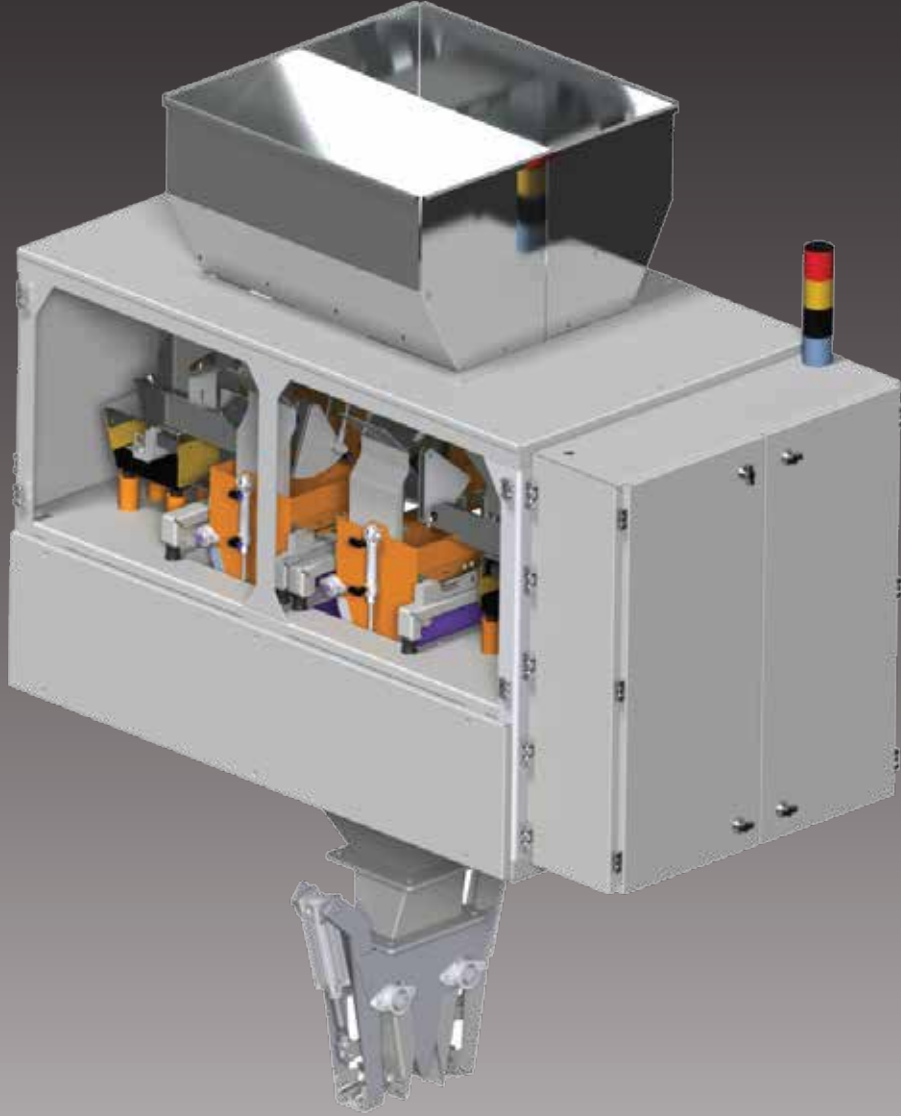

Dört Kefeli Linear Terazı

Four Multi Head Scale

Четыре-глава линейных шкал



www.akyurektech.com



ISO 9001 - 2008
QUALITY ASSURANCE

Ürün Kodu/Product Code

Dört Kefeli Linear Terazi - Four Multi Head Scale

Четыре-глава линейных шкал

Granül yapıdaki tüm ürünlerin hızlı, hassas ve el değmeden tartılması amacıyla tasarlanmış sistemdir. Lineer terazilerimiz istenilen kapasiteye göre tekli ve çok kefeli sistem olarak imal edilir. Her türlü ürünü hassasiyetle tartar, bakım gerektirmez, paslanmaz çelikten üretildiği için kolaylıkla yıkanabilir. Ürün geçişleri kolaydır, ürüne hiçbir zarar vermez.

It is a system which has been designed with the aim of being weighed of all the products in granule structure rapidly, sensitively and untouched by human hands. Its designed for all the granur group to be weight as rapid, precision and untouched system. Our Linear Scales are manufactured single and multi-head system according to the desired capacity. It weighs all kinds of products sensitively, maintenance free, and as its produced from stainless steel easily washable. Products transitions are easily. It does not damage the product.

Целью производства: Вся продукция гранулированный, быстро, точный и полностью автоматизированное производство. Производство в зависимости от нуждающихся в емкости, одно-и несколькими головками. Весит в любой продукт, необслуживаемые, изготовлены из нержавеющей стали и поэтому можно мыть. Переходы продукта легки поэтому не принесет вреда на продукт.

Hızlı Dolum Kanalı
Quick Filling Channel

Быстрое заполнение канала

Hassas Dolum Kanalı
Sensitive Filling Channel

точное заполнение

Hassas Dolum Vibratörü
Sensitive Filling Vibrator

точное заполнение с вибратором

Manyetik Vibratör
Magnetic Vibrator

магнитного вибратора

Vibrasyon Takozu
Vibration Mount

опоры для предотвращения вибрации

Tartım Haznesi Pistonu
Weighing Hooper Piston

весовой бункер поршневой

Tartım Haznesi
The Weighing Hooper

Весовой бункер



Ürün Giriş
Product Input
Вход продукт

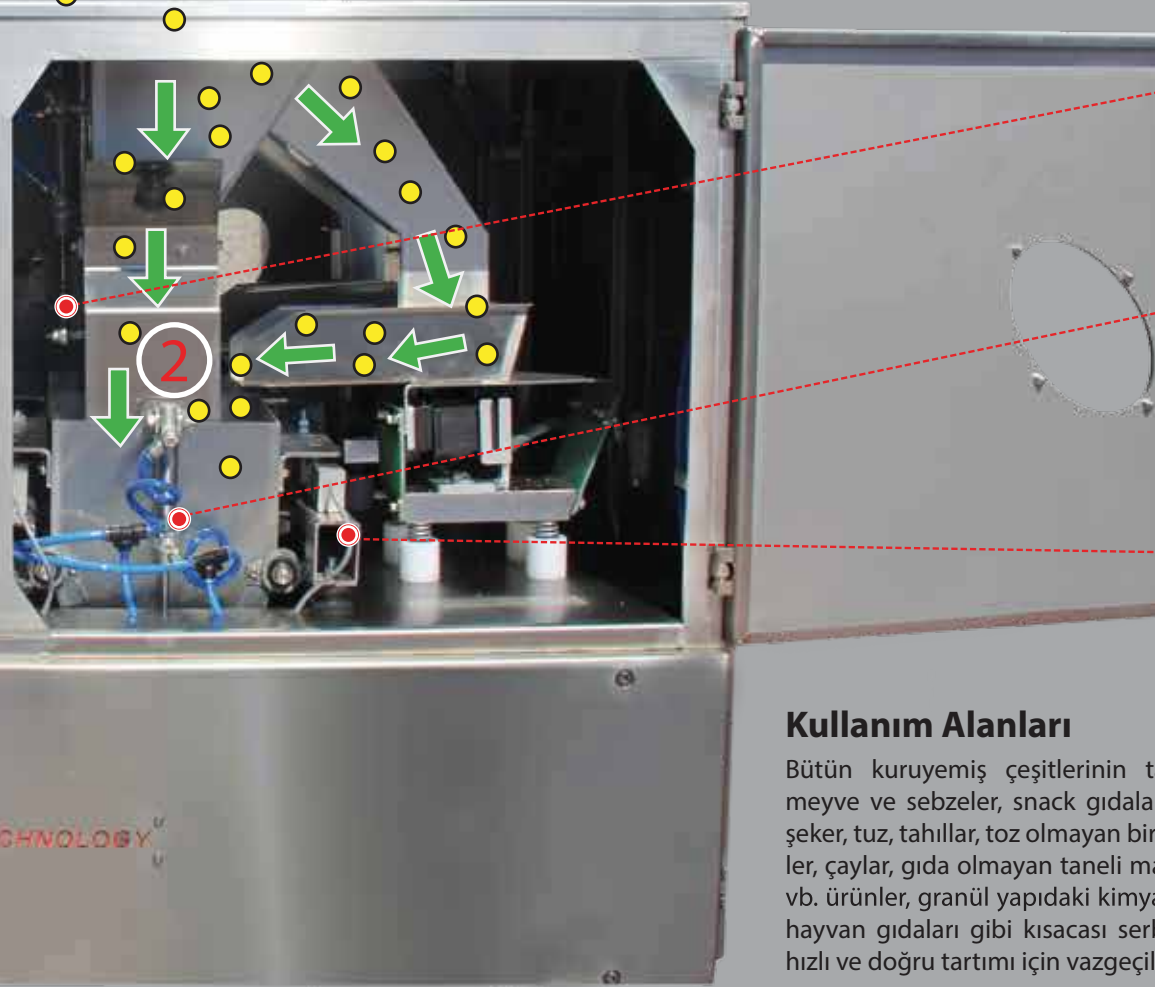
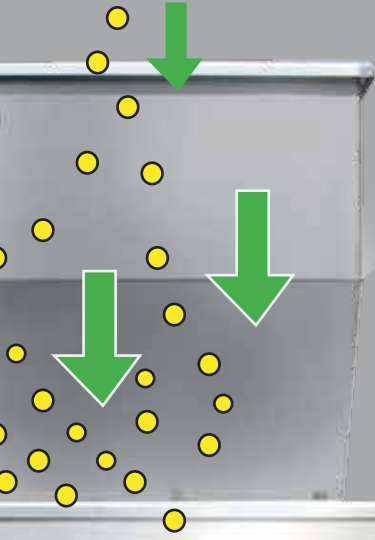

Hızlı Dolum Pistonu
Quick Filling Piston

Быстрое наполнение
поршня

Piston
Piston

Поршень

Loadcell
Load cell

ячейка загрузки

Kullanım Alanları

Bütün kuruyemiş çeşitlerinin tartımı, bakliyatlar, kurutulmuş meyve ve sebzeler, snack gıdalar, rendelenmiş peynir, deterjan, şeker, tuz, tahıllar, toz olmayan birçok baharat çeşitleri, şekerlemeler, çaylar, gıda olmayan taneli maddeler, vida, somun, pul, civata vb. ürünler, granül yapıdaki kimyasal ürünler, tohum, torflar, evcil hayvan gıdaları gibi kısacası serbest düşebilen bütün ürünlerin hızlı ve doğru tartımı için vazgeçilmez terazilerdir.

The Usage Areas

Weighing all kinds of nuts, legumes, dried fruits and vegetables, snack foods, grated cheese, detergents, sugar, salt, grains, many non-powdered spices, candies, teas, non-food granular materials, screws, nuts, washers, bolts and so on. products, granular chemical products, seeds, torflar, such as pet food... Shortly It is fast, accurate and indispensable scale for the products which are fall free.

Область применения

Взвешивания все виды орехов , бобовые , сушеные фрукты и овощи , закуски , тертого сыра , моющее средство , сахар , соль , зерна , беспыльный приправы продуктами, Кондитерский , чаев , зернистый непродовольственные товары , винта , гайка , шайба , болт , и так далее продукты , гранулированных химических продуктов , семена , торф , корм , короче говоря, незаменимый для быстрого и точного взвешивания свободно падающих всех продуктов.



ISO 9001
QUALITY ASSURANCE

İndikatör + PLC = Hassas ve Hızlı Tartım - Indicator + PLC = Precision and Rapid Weighing

Индикаторы + ПЛК = Точная и быстрая взвешивания

Sistemde 4 adet indikatör loadcellere direk bağlıdır. Kilo ve açma kapama bilgileri indikatör tarafından yapılarak, hızlı bilgi alışverişi ve hassasiyeti kontrol eder. İndikatörlerden bu sayede maksimum verim alınmış olur. Kullanıcıya kolaylık olması açısından PLC ve touch panel ile desteklenen sistem, makinenin kolay ayarlanabilmesi yapılan ayarların hafızada saklanabilmesi, çeşitli ürünlerde makine kalibrasyonu kolaylaştırır. Farklı ayar modları vardır. Makede meydana gelen hatalı tartımlar, arızalar, üretim bilgileri, yapılan tartım miktarları, adetler vs. gibi tüm bilgiler PLC hafızasında saklanarak günlük bilgi raporu verir. PLC 'den alınabilecek maksimum verim alınarak kullanıcıya kolaylık sağlanmış olur.



The system is directly related to 4 pieces indicator load cell. Weight and on-off information are provided by the indicator and thus controls quick Exchange of information and its sensitivity. Thus, maximum output is obtained from the indicators. With regards to provide to the user convenience, the system supported by PLC and touch panel facilitates the adjustment of the machine easily, keeping in the storage and calibration of the machine in various products. It has different tuning modes. It gives a daily information report about a information such as, faulty weighing, malfunctions, manufacturing information, weighing output and items committed by saving in PLC storage. By taking maximum output that can be obtained from PLC, the facility will be provided for the user

4 датчика индикатора напрямую связана с системой. Информации, вес и открытием и закрытием являются с помощью индикатора. Контролирует быстрый обмен информацией и и точности. Так что максимальная эффективность достигается. Поддерживаемые системы с ПЛК и сенсорная панель, легкая регулировка, настройки сохранить в памяти, все эти в различных продуктов облегчает калибровки машины. Существуют различные режимы настройки. Происходящие неправильных весов, сбой, данные по добыче, количествах взвешивания, штуки и т.п.. Вся информация хранится в памяти ПЛК и дает ежедневный отчет информации.

Kumanda paneli içerisinde başta Schneider Electric olmak üzere en kaliteli malzemeler ve kontrol cihazları kullanılmıştır. Makinenin görevi gereğince hassas tartım yaptığı için malzemelerden kaynaklanacak olan hataları ortadan kaldırmak için gere tüm önlemler alınmış olup insan güvenliği için tüm kurallar uygulanmıştır.

Especially the highest quality Schneider, the top quality materials and control devices have been used in control panel. Because the machine is weighing sensitively by virtue of its mission in order to remove the malfunctions to be derived from the materials all the precautions have been taken and all the regulations have been applied



Панель управления высочайшего качества Шнайдера, использованы материалы высшего качества и устройств управления. Все правила были применены к безопасности человека.



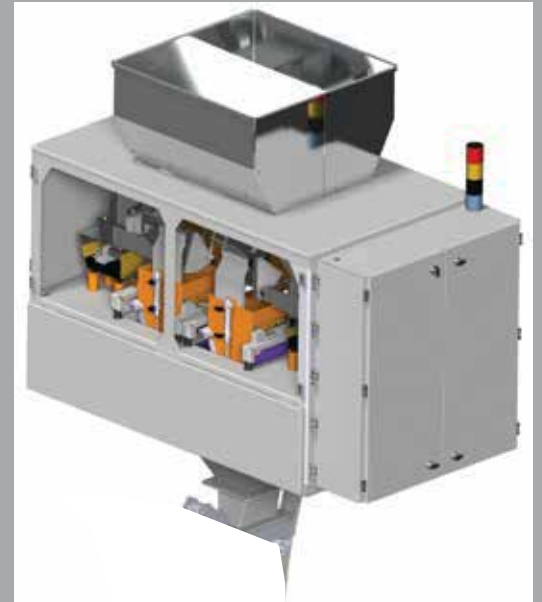
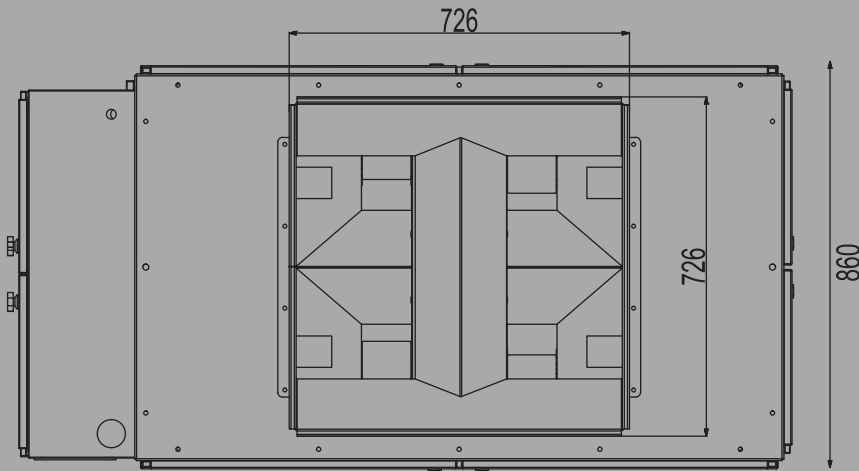
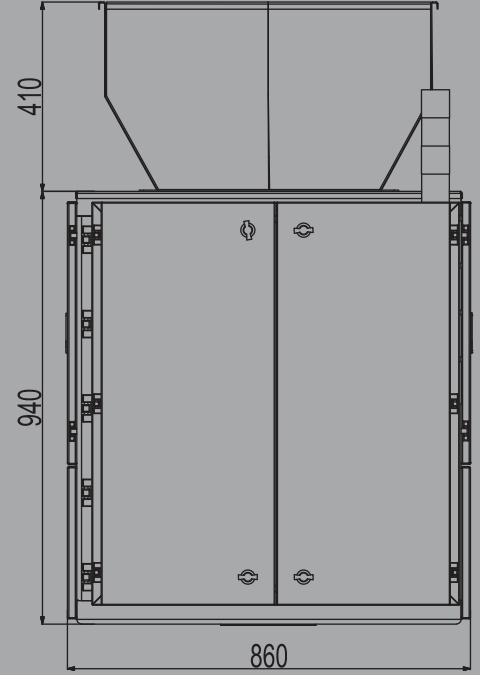
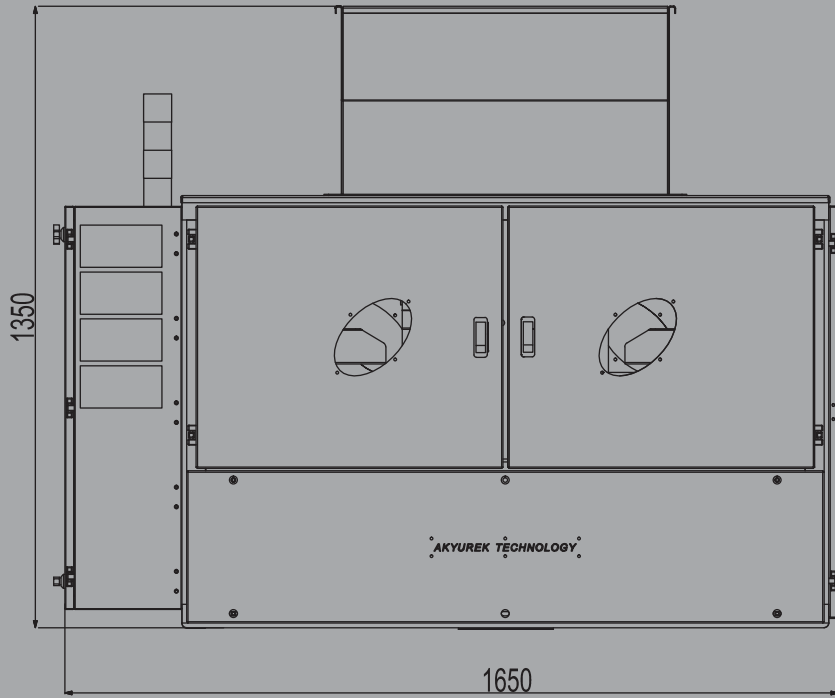

ÖZELLİKLER - SPECIFICATIONS - ФУНКЦИИ

Madde--İtem – Пункт	İçerik - Contents - Содержание
Model- Model – Модель	LINEAR MX4J
Maksimum Ağırlık - Gross Weight - Максимальный вес	370 kg - КГ
Makine Boyutu - Dimension of the machine Размер машины	1650 mm X 1350 mm X 860 mm
Tartım Aralığı - Maximum weight - Максимальный вес	1 - 5 kg - КГ
Tartım Hassasiyeti (İri ürünlerde farklılık göstermektedir.) Weighing Range (Precision of weighing shows differences in large products.) точность взвешивания в большой продукт показывает различие	1 - 5 gr - Гр
Kefe Sayısı - Number of Scales - Количество Весы	4
Her kefedeki kullanılan loadcell sayısı Number of Load Cell Used in Each Scale За Каждый Весы Количество Ячейка Загрузки	2
Sarsak Sayısı - Oscillating Number - Электромагнитный Питатель	4
Kumanda Şekli - Control Type - Методы Контроля	PLC Dokunmatik Ekran Plc touch screen - ПЛК сенсорный экран
Makine Gürültü Düzeyi - Machine Noise Level Уровень Шума Машины	76 Desibel Maksimum
Makine Rengi - Machine Color - Цвет Машины	Parlak Krom Clear Chromium - полированный хром
Standart Gerilim - Standard Voltage Стандартное Напряжение	380 V 3 kw
Makine İmalat Malzemesi Machine Manufacturing Material Производственный Материал Для Машинка	304 Krom 304 Chromium 304 хром



- Naturel Ürün / Natural Product / **Натуральные Продукты**
- Hızlı Dolum / Quick Filling / **Быстрое Заполнение**
- Hasas Dolum / Sensitive Filling / **Точное Заполнение**
- Hasas Tartım / Precious Weighing / **Точность Взвешивания**
- Tartılan Ürün / Weighed Product / **Взвешиваемый Продукт**

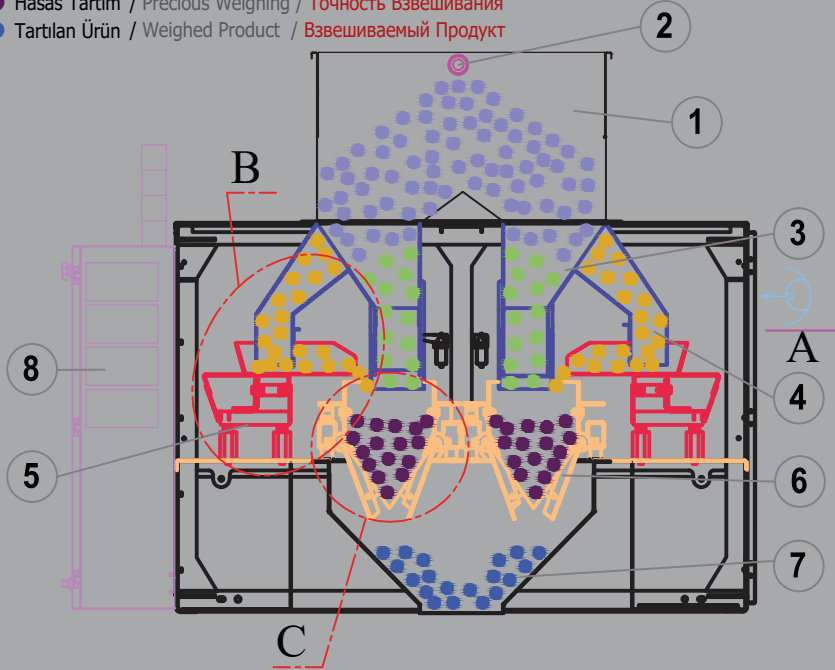

- 1 - Besleme Bunkeri
- 2 - Hızlı dolum kanalı
- 3- Hassas dolum kanalı
- 4- Besleme bunkeri seviye sensörü
- 5- Sarsak
- 6- Hassas tartım kefesi
- 7- Ürün çıkış kanalı
- 8- Kumanda paneli

- 1 - Feeding Bunker
- 2- Rapid Filling Channel
- 3- Sensitive Filling Channel
- 4- Level Sensor of Feeding Bunker
- 5- Vibration
- 6- Sensitive Weighing Scale
- 7- Product Output Bunker
- 8- Control Panel

- 1 - Загрузочные бункеры
- 2- быстрое заполнение бункеры
- 3- Точное заполнение бункеры
- 4- Загрузочный бункер датчика уровня
- 5- вибрация
- 6- Точность весов
- 7- выход продукта
- 8- Панель управления

Hızlı Dolum Klapesi
Rapid Filling Valve
Быстрогo заполнения Клапана

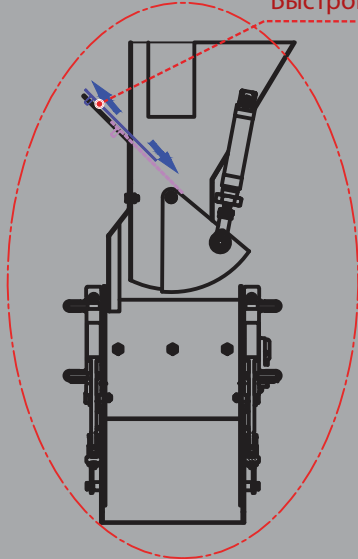

A Detayı
A Detail
Детали А

Hassas Dolum Klapesi
Sensitive Filling Valve
Точное заполнение клапана

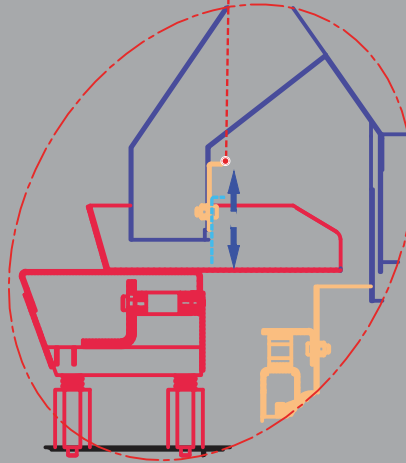

B Detayı
B Detail
Детали Б

Kefe Klapesi
Scale Valve
шкала клапана

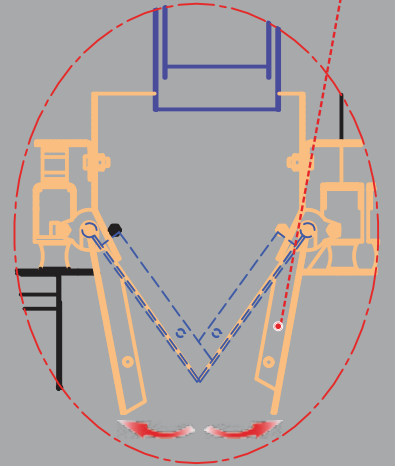

C Detayı
C Detail
Детали С



Representatives

Bulgaria
Company / Person: TECHNOMASH INVEST
LTD Veli AHMEDOV - Guner TUNA
Address: 7000 Rousse, Tsar Ferdinand 32,
Office 1
Country: Bulgaria
City: Rousse
Phone: +359 82596309
Fax: +359 82596309
Mail: tmi@tmi-bg.com

Romania
Company / Person: A.S.I. SC. AGRITRANS
SERVICE INTERNATIONAL SRL
Country: Romania
City: CONSTANTA
Phone: 00 40 744 633380
Fax: 00 40 341 816811
Mail : office@agritrans.ro

Etiyopya
Company / Person: ALPHA TRADING
PARTNER PLC.
Address: P.O. Box 1533 code 1250
Country: Etopya
City: Addis Ababa
Phone: 00 251 11 515 1920
00 251 11 552 8084
Fax: 00 251 11 552 80855
Mail: 00 251 11 552 80855

Israel
Company / Person: DAGAN GRAINS & SEEDS
Address: Moshav Beer Tuvia
Country: Israel
City: Isreal
Phone: 00 972 8 858 0808
Fax: 00 972 8 850 3646
Mail: amos@synergypet.co.il

Malaysia
Company / Person: AGRO INDUSTRIAL
SUPPLIES (M) SDN. BHD.
Address: Lot 25-28&32, Kaw. Perushaan Bandar
Darulaman, 06000 Jitra, Kubang Pasu, Kedah
Darul Aman
Country: Malaysia
City: Malaysia
Phone: 00 6 04 917 9591
Fax: 00 6 04 917 9596
Mail: info@agro-indus.com

Indonesia
Company / Person: AGRO INDUSTRIAL
SUPPLIES (M) SDN. BHD.
Address: Lot 25-28&32, Kaw. Perushaan Bandar
Darulaman, 06000 Jitra, Kubang Pasu, Kedah
Darul Aman
Country: Indonesia
City: Malaysia
Phone: 00 6 04 917 9591
Fax: 00 6 04 917 9596
Mail: info@agro-indus.com

Syria
Company / Person: KASIM IBO
Address: Aleppo-Solymanya
Country: Syria
City: Aleppo
Phone: 00963933098261
Fax: 00963214668030
Mail: k-ibo.co@hotmail.com

Cambodia
Company / Person: AGRO INDUSTRIAL
SUPPLIES (M) SDN. BHD.
Address: Lot 25-28&32, Kaw. Perushaan Bandar
Darulaman, 06000 Jitra, Kubang Pasu, Kedah
Darul Aman
Country: Cambodia
City: Malaysia
Phone: 00 6 04 917 9591
Fax: 00 6 04 917 9596
Mail: info@agro-indus.com

Vietnam
Company / Person: AGRO INDUSTRIAL
SUPPLIES (M) SDN. BHD.
Address: Lot 25-28&32, Kaw. Perushaan Bandar
Darulaman, 06000 Jitra, Kubang Pasu, Kedah
Darul Aman
Country: Vietnam
City: Malaysia
Phone: 00 6 04 917 9591
Fax: 00 6 04 917 9596
Mail: info@agro-indus.com

Thailand
Company / Person AGRO INDUSTRIAL
SUPPLIES (M) SDN. BHD.
Address: Lot 25-28&32, Kaw. Perushaan Bandar
Darulaman, 06000 Jitra, Kubang Pasu, Kedah
Darul Aman
Country: Thailand
City: Malaysia
Phone: 00 6 04 917 9591
Fax: 00 6 04 917 9596
Mail: info@agro-indus.com

Philippines
Company / Person AGRO INDUSTRIAL
SUPPLIES (M) SDN. BHD.
Address: Lot 25-28&32, Kaw. Perushaan Bandar
Darulaman, 06000 Jitra, Kubang Pasu,
Kedah Darul Aman
Country: Philippines
City: Malaysia
Phone: 00 6 04 917 9591
Fax: 00 6 04 917 9596
Mail: info@agro-indus.com

Poland
Company / Person: BROMEX
Address: 99-400 Lowicz, ul. Nadbzurzanska 28
Country: Poland
City: POLAND
Phone: 00 48 43 67 68 901
Fax: 00 48 43 67 68 902
Mail: broniarek@bromex.com.pl

Sudan
Company / Person: ABDALLA ELMAHAL
COFFTEA TRADING LTD
ALGAMHORIA STR. COFFTEA BUILDING
KHARTOUM
Country: Sudan
City: SUDAN
Phone: 00249183774530
Mail: elmahal@hotmail.com

Nigeria
Company / Person: Ramzi TAHER
RMM Global Company
7 MAI Malavi Road
Country: Nigeria
City: Kano
Phone: +234 0 64 988181
Mail: knrmmkn@yahoo.com

Представители

Bulgaria
О компании / Лица TECHNOMASH INVEST
LTD- Veli AHMEDOV - Guner TUNA
Страна: Bulgaria
Город: Rousse
Телефон: +359 82596309
Факс: +359 82596309
Почта: tmi@tmi-bg.com



Romania
О компании / Лица A.S.I. SC. AGRITRANS
SERVICE INTERNATIONAL SRL
Страна: Romania
Город: CONSTANTA
Телефон: 00 40 744 633380
Факс: 00 40 341 816811
Почта: office@agritrans.ro

Ethiopia
О компании / Лица ALPHA TRADING
PARTNER PLC.
Address: P.O. Box 1533 code 1250
Страна: Ethiopia
Город: Addis Ababa
Телефон: 00 251 11 515 1920
00 251 11 552 8084
Факс: 00 251 11 552 80855
Почта: 00 251 11 552 80855

Israel
О компании / Лица DAGAN GRAINS & SEEDS
Address: Moshav Beer Tuvia
Страна: Israel
Город: Isreal
Телефон: 00 972 8 858 0808
Факс: 00 972 8 850 3646
Почта: amos@synergypet.co.il

Malaysia
О компании / Лица AGRO INDUSTRIAL
SUPPLIES (M) SDN. BHD.
Address: Lot 25-28&32, Kaw. Perushaan Bandar
Darulaman, 06000 Jitra, Kubang Pasu,
Kedah Darul Aman
Страна: Malaysia
Город: Malaysia
Телефон: 00 6 04 917 9591
Факс: 00 6 04 917 9596
Почта: info@agro-indus.com

Indonesia
О компании / Лица AGRO INDUSTRIAL
SUPPLIES (M) SDN. BHD.
Address: Lot 25-28&32, Kaw. Perushaan Bandar
Darulaman, 06000 Jitra, Kubang Pasu, Kedah
Darul Aman
Страна: Indonesia
Город: Malaysia
Телефон: 00 6 04 917 9591
Факс: 00 6 04 917 9596
Почта: info@agro-indus.com

Syria
О компании / Лица KASIM IBO
Address: Aleppo-Solymanya
Страна: Syria
Город: Aleppo
Телефон: 00963933098261
Факс: 00963214668030
Почта: k-ibo.co@hotmail.com

Cambodia
О компании / Лица AGRO INDUSTRIAL
SUPPLIES (M) SDN. BHD.
Address: Lot 25-28&32, Kaw. Perushaan Bandar
Darulaman, 06000 Jitra, Kubang Pasu, Kedah
Darul Aman
Страна: Cambodia
Город: Malaysia
Телефон: 00 6 04 917 9591
Факс: 00 6 04 917 9596
Почта: info@agro-indus.com



Vietnam
О компании / Лица AGRO INDUSTRIAL
SUPPLIES (M) SDN. BHD.
Address: Lot 25-28&32, Kaw. Perushaan Bandar
Darulaman, 06000 Jitra, Kubang Pasu, Kedah
Darul Aman
Страна: Vietnam
Город: Malaysia
Телефон: 00 6 04 917 9591
Факс: 00 6 04 917 9596
Почта: info@agro-indus.com

Thailand
О компании / Лица AGRO INDUSTRIAL
SUPPLIES (M) SDN. BHD.
Address: Lot 25-28&32, Kaw. Perushaan Bandar
Darulaman, 06000 Jitra, Kubang Pasu, Kedah
Darul Aman
Страна: Thailand
Город: Malaysia
Телефон: 00 6 04 917 9591
Факс: 00 6 04 917 9596
Почта: info@agro-indus.com

Philippines
О компании / Лица AGRO INDUSTRIAL
SUPPLIES (M) SDN. BHD.
Address: Lot 25-28&32, Kaw. Perushaan Bandar
Darulaman, 06000 Jitra, Kubang Pasu, Kedah
Darul Aman
Страна: Philippines
Город: Malaysia
Телефон: 00 6 04 917 9591
Факс: 00 6 04 917 9596
Почта: info@agro-indus.com

Poland
О компании / Лица BROMEX
Address: 99-400 Lowicz, ul. Nadbzurzanska 28
Страна: Poland
Город: POLAND
Телефон: 00 48 43 67 68 901
Факс: 00 48 43 67 68 902
Почта: broniarek@bromex.com.pl

Sudan
О компании / Лица ABDALLA ELMAHAL
COFFTEA TRADING LTD
ALGAMHORIA STR. COFFTEA BUILDING
KHARTOUM/SUDAN
Страна: Sudan
Город: SUDAN
Телефон: 00249183774530
Почта: elmahal@hotmail.com

Nigeria
Представитель : Ramzi TAHER
Компания : RMM Global Company
Адрес : 7 MAI Malavi Road
Город: Kano
Страна: Nigeria
Телефон: +234 0 64 988181
Эл. Почта: knrmmkn@yahoo.com



Akyürek Teknoloji Makina A.Ş.

Karaduvar Mahallesi 65117 Sokak
No : 37-A MERSİN/TÜRKİYE
Telefon : 444 6 259
E - Posta : info@akyurektech.com
Web : www.akyurektech.com



Akyürek Teknoloji Makina A.Ş.

Karaduvar Avenue 65117 Street
No : 37-A MERSİN/TÜRKİYE
Phone : 444 6 259
E - Mail : info@akyurektech.com
Web : www.akyurektech.com

www.akyurektech.com

Akyürek Teknoloji Makine A.Ş. have all the copyrights of the information and pictures provided in this catalogue. We have all rights to do necessary adjustments on the product & these changes may not reflect on the catalogue at the moment of production. we will do our upmost to indorm you all the changes if and we.



ISO 9001 - 2008
QUALITY ASSURANCE

+90 444 6 259